

MINI MK7 EVOLUTION BURNER MANAGEMENT SYSTEM

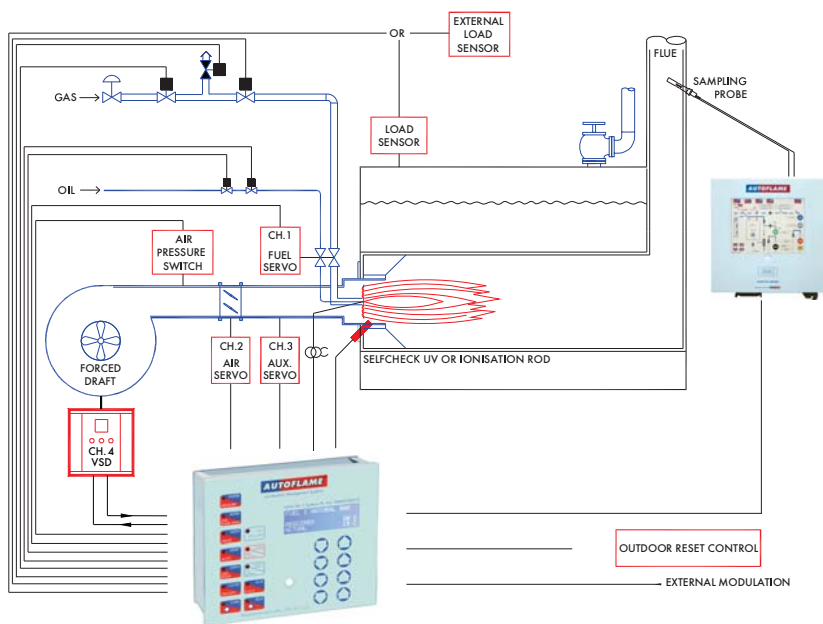

OUTDOOR RESET (Outside Temperature Compensation)

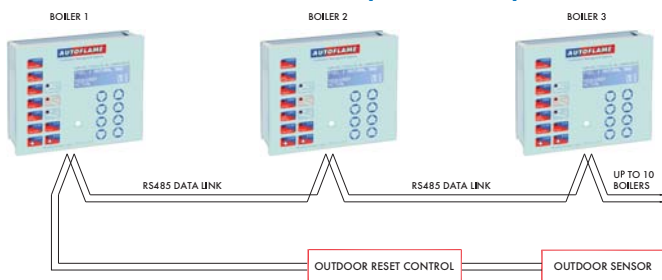

Main Features and Benefits

- Micro Modulation - fuel/air ratio control
- 2 Fuel curve capability
- 3 Servomotor channel control
- 1 VSD channel control
- Internal flame safeguard control
- UV and IR detection
- Self-Check UV detection
- Ionisation Rod detection
- Lead Lag (Intelligent Boiler Sequencing - IBS)
- Precise target setpoint control (PID)
- 3 Parameter trim, O₂, CO₂ & CO
- FGR Management
- Outdoor reset
- NFPA compliant
- NEMA4/IP65 enclosure
- Keypad push button control

To ensure maximum efficiency in the operation of any boiler, two requirements are of paramount importance. The first being that the air to fuel ratio is kept to the minimum to ensure complete combustion within the limitations of the combustion head design and that these settings, once arrived at, are infinitely repeatable to an incredibly high degree of accuracy.

The second requirement should be that the target temperature or pressure of the boiler is monitored by the combustion system, and that at all times exactly the right amount of fuel and air is fired to achieve the target value.

The inherent hysteresis of all mechanical systems that have traditionally involved cams and linkages to characterise the fuel/air ratio have made this sort of accuracy impossible. The accuracy of response of fuel input to the monitored target temperature/pressure of the boiler has meant that the target set by the operator has at most times been exceeded or fallen short of. Autoflame Engineering were the first in the World to develop a system that overcomes all these problems by utilising the latest micro processor technology.

The Micro Modulation system provides an easily programmable and flexible means of optimising combustion quality throughout the load requirement range of the boiler/burner unit whilst ensuring the temperature is accurate to within 1°C (2°F) and pressure to within 1.5 p.s.i. The positioning accuracy of the direct drive motors controlling the air damper and fuel valve is 0.1 angular degrees throughout the load range. At the heart of the system is the control module which contains the micro computer and power supply. The front panel of the control module features a touch sensitive keypad for data entry and an LCD display.

Mini Mk7 Evo M.M. Features & Benefits

Micro Modulation Fuel/Air Ratio Control

- Independently controlled fuel and air positioning motors with an accuracy of 0.1 of an angular degree
- 2 separate fuel curves
- 3 servo drives and 1 VSD
- 20 x 4 line LCD Display
- Error diagnostic codes displayed
- Single point change facility for commissioned fuel/air ratio
- User definable optimum ignition position
- FGR management - delay from start-up of FGR until exhaust temperature, boiler setpoint or time delay achieved

Exhaust Gas Analyser (separate module)

- O₂, CO₂, CO trim, NO, SO₂ and NO₂ continuous monitoring and display
- User definable combustion limits on O₂, CO₂, CO, NO and exhaust gas temperature
- Exhaust, ambient temperature and ΔT displayed
- Combustion efficiency calculation – net or gross displayed
- Local display for automatic calibration

Burner Control Box Functions

- Full flame supervision with Self-check UV or ionisation flame detection
- Burner control functions with user configurable timings
- Lockout history of last 16 incidents with date, time & function

User Features

- Password protection, user configurable options and parameters
- IRCOM's port for upload/download of commissioned data and operating history
- All systems data exports via gateway (Modbus/Metasys)
- Internal calendar clock display and logging functions

Setpoint Control Features

- Internal 3 term PID control to maintain required setpoint for both pressure and temperature
- Software adjustable thermostat/pressure stat. facility
- Lead-lag for both steam and hot water
- Lead boiler select facility on facia
- 2 port valve operation for hot water sequencing
- Fuel Flow Metering – instantaneous and totalised
- Hand/Auto/Low flame hold facilities on facia
- 0-10V input for external modulation
- Ability to use external temperature and pressure detectors
- Outdoor reset (outdoor temperature compensation)

Key Pad Push Buttons

Touch keypad incorporates conventional push buttons typically used on the burner control panel to help minimise the cost and need for external wiring and components:

- Low Flame Hold
- Hand
- Auto
- Lockout Reset
- Lead Boiler Select
- Burner On/Off
- Setpoint Adjust

External Inputs

- VPS - Gas Valve Proving Switch
- External Modulation (0-10V)
- Low Fire Interlock
- High Purge Interlock
- External Load Sensor

Specifications

- 120/230V, 50/60 Hz switchable standard operation
- IP65/NEMA 4 enclosure with panel facia mounting
- Manufactured under BS EN ISO 9001:2000



Peripherals:



Positioning Motors

Load Detectors

Flame Scanners

Pressure Sensors

Autoflame Software

Autoflame Engineering Ltd.

Telephone: +44 (0)845 872 2000 Fax: +44 (0)845 872 2010

Email: salesinfo@autoflame.com Website: <http://www.autoflame.com/>

