

LED COLOURS  
G - GREEN  
R - RED  
Y - YELLOW

DRAIN  
16 WAY PLUG  
(MAINS POWER SUPPLY)

16 WAY SOCKET  
(DATA CABLE & 4-20mA)



## Main Features and Benefits

- TFT 10.4" VGA full colour touch screen interface for automatic calibration
- Automatic timed test gas (span gas) calibration (EPA only)
- Heated/insulated sample line (EPA only)
- Continuous measurement of flue gas (O<sub>2</sub>, CO, CO<sub>2</sub>, NO, SO<sub>2</sub> and NO<sub>2</sub>)
- Micro processor controlled
- Full diagnostics
- Low maintenance
- Low cost and easy installation using plug-in connectors
- Online instantaneous and totalised logging
- Full continuous emissions monitoring software for display and full data logging
- Six 4-20mA analogue output signals (gross or net combustion efficiency %, exhaust gas temperature F or C)
- Three parameter trim on O<sub>2</sub>, CO and CO<sub>2</sub>
- Upper and lower limits controls on five measured combustion parameters O<sub>2</sub>, CO, CO<sub>2</sub>, NO and Exhaust Gas Temperature
- Both stand-alone and MM operation
- Results from the EGA can be downloaded to a data acquisition system via the Autoflame Data Transfer Interface (DTI)
- Environmental enclosure available on request for non-standard ambient conditions

## 10.4" Touch Screen Display

- Time/Date facility and error log
- EGA system configuration, cell replacement and automatic calibration
- Hours run and cell selection for each fuel
- Data logging

## Technical Specification

Part Number	MM72004
Power Supply	230V 50Hz/120V 60Hz
Ambient Temp Limit	+41 F/+104 F (5 C/40 C)
Environmental Rating	IP20

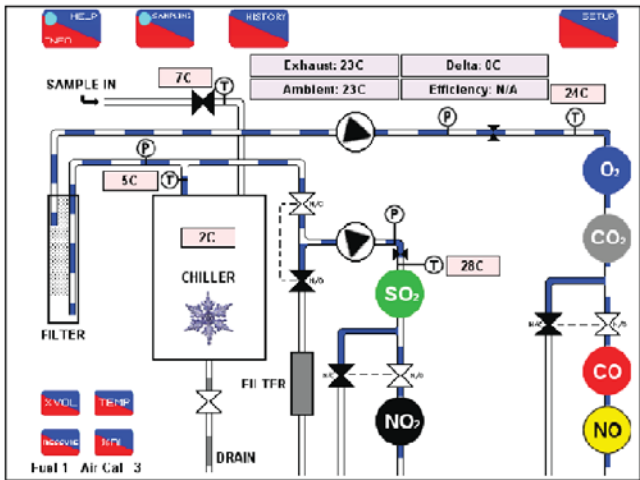

**Technical specification**

A maximum of 6 x 4-20mA output signals are available. In addition to the above, signals are available for:

- Combustion efficiency % (a calculation of O<sub>2</sub> and temperature)
- Exhaust gas temperature (degrees Celsius or Fahrenheit)

This complete system can be used for continuous measurement of flue gas and the results can be downloaded to a data acquisition system via the Autoflame Data Transfer Interface (DTI).

**EGA Combustion Trim Operation with Micro Modulation (MM)**

Using the output signals for O<sub>2</sub>, CO, CO<sub>2</sub> and NO from the EGA it is possible to expand the Autoflame Micro Modulation (MM) unit so that the software will inflict minute corrections to the air damper or the fan speed drive. These minute changes ensure that the originally entered commissioning data is adhered to irrespective of variations in stack pressure or barometric conditions.

**Limits on Three Measured Combustion Parameters O<sub>2</sub>, CO, CO<sub>2</sub>**

The limits control software, which is available in the MM module, further extends the application and control possibilities of the system when the EGA unit is used. The function of the limits control software enables the end user or commissioning engineer to insert upper and lower control limits for O<sub>2</sub>, CO<sub>2</sub>, CO.

**Automatic Calibration**

By the use of the rear mounted manifold enclosure it is possible to automatically calibrate all six sensors located within the E.G.A. enabling full compliance to MCERT's and EPA legislation.

**Technical Specifications**

Part Number	MM72004/MM10033
Power Supply	230V 50Hz/110V 60Hz
Ambient Temperature Limits	+5°C to +40°C
Environmental Rating	IP65/NEMA 4 enclosure with panel facia mounting

Up to 6 x 4-20mA Output Signals Available

